

Aug. 28, 1956

A. G. E. D'ALTON ET AL
PYROPHORIC SMOKER'S LIGHTER

2,760,364

Filed Feb. 24, 1953

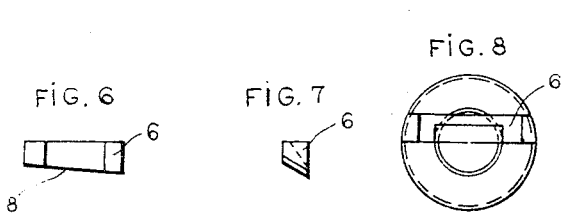
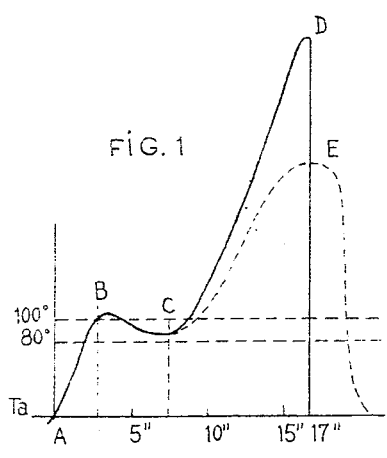
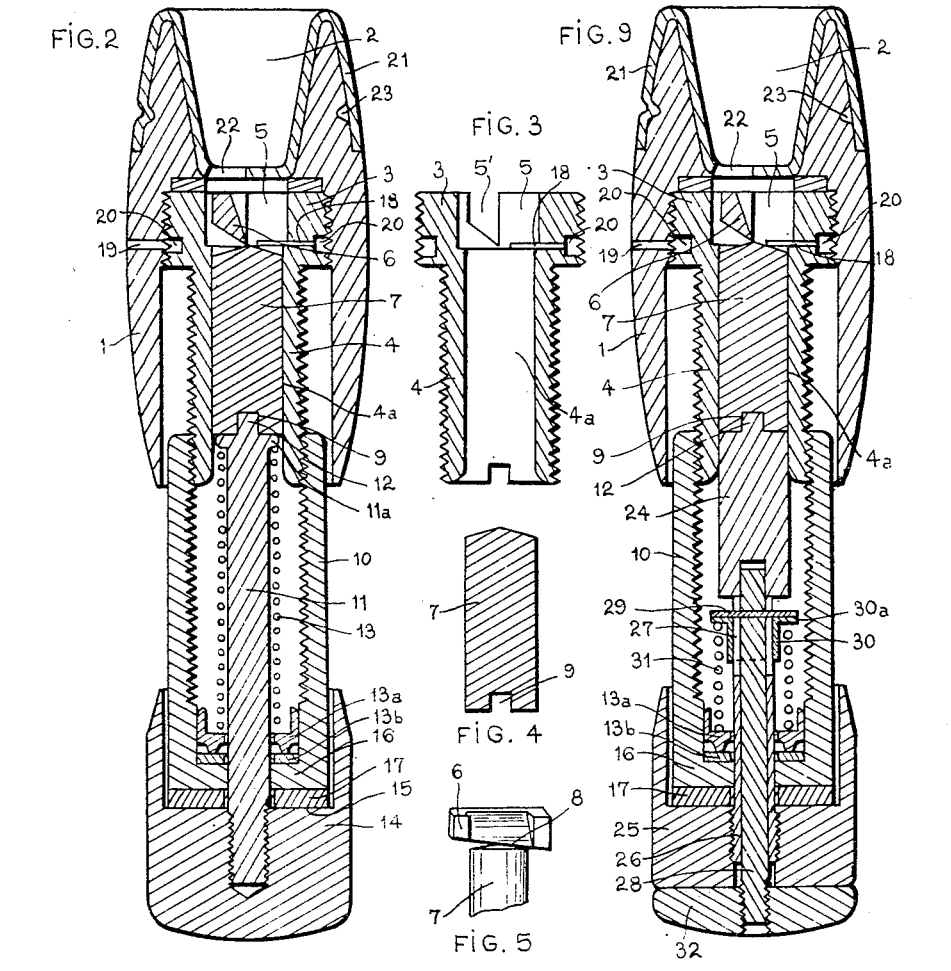

1

2,760,364

PYROPHORIC SMOKER'S LIGHTER

André Gaston Edouard d'Alton and Edouard Alfred
Henri William d'Alton, Paris, France

Application February 24, 1953, Serial No. 338,516

Claims priority, application France February 2, 1953

5 Claims. (Cl. 67—7.1)

Pyrophoric lighters for smokers, with a direct ignition of the tobacco by contact with pyrophoric particles, have been already proposed wherein the end of the pyrophoric rod and a movable abrasive member are contained in a chamber of small size, provided with a duct to discharge on the tobacco the stripped particles and with a small port for the inlet of air.

In the particular embodiment previously described, the abrasive member is a small cutting wheel rotated as usually about an axis perpendicular to the longitudinal axis of the pyrophoric rod and the discharge duct for the projection of ignited particles is directed along a tangent to this wheel at the stripping point and is conveniently shaped to allow the insertion of the end of the cigarette or the cigar, or of the bowl of the pipe.

According to this previous invention, the lighter can be used in two ways:

Either the smoker starts first with a slow stripping, ejecting on the tobacco pyrophoric particles which are not very heated and, mostly, are not immediately ignited, then, with a swift stripping, discharges ignited particles which when coming in contact on the tobacco with the first particles ignite them whilst the smoker, by inhaling through the tobacco, accelerates the ignition and starts thereby the combustion of the tobacco.

The smoker starts immediately with a swift stripping, projecting ignited particles on the tobacco and inhales in same time through the tobacco, to start its combustion.

Practice has shown that, in both cases, the lighting is not absolutely secured.

The chief reasons are: the fineness of the particles stripped by the revolving wheel, the too fast combustion of these particles, the scattering of the heat in the metallic mass of the lighter. In addition, on account of the comparatively large diameter to be given to the revolving wheel to secure a sufficient stripping speed, the nearly closed chamber, in which is set this wheel is partly empty and contains thereby a mass of air comparatively important in proportion to the mass of stripped particles: this air becomes accelerated on account of the rotation of the small wheel and it is difficult, even in the case of a slow rotation to prevent or to delay as much as desired, the combustion of the particles. The very thin dust penetrates all the mechanisms which become quickly useless. To end, some individuals experience difficulty to achieve simultaneously the two operations, the management of the lighter and the inhalation.

The present invention is concerned with an improvement of the above mentioned patent due to an improved ignition cycle for the pyrophoric particles and an improved embodiment of the lighter, meeting the above mentioned drawbacks.

This process for the improved lighting of a combustible material by means of ignition of pyrophoric bodies, such for instance, as ferro-cerium, can be applied to the lighting of a large number of combustible materials, particularly of tobacco.

The process consists in accumulating, without stirring it, a mass of fairly pyrophoric particles in a chamber

2

or crucible, sheltered against any gaseous turbulence, in bringing said particles to an initial temperature corresponding to a very slow combustion, unable to give rise in the chamber to a rapid combustion of this mass, then, in bringing in contact, or in close vicinity, the material to be lighted and this mass and initiating afterwards in the chamber an instantaneous and complete combustion of the mass of particles by the controlled action of a strong gaseous turbulence.

According to the invention, the device to carry out this process is characterized in that, in order to produce, without stirring and without turbulence, and to heat a concentrated mass of fairly large pyrophoric particles, it includes a crucible of small size, made preferably of a thermo-insulating material, and, in an opening at the bottom of the crucible, a cutting tool such as a lathe-tool, a cutter, a milling-cutter, cooperating with a small pyrophoric rod to strip particles off said small rod.

Preferably the cutting tool is fast and the small pyrophoric rod is rotated about its longitudinal axis.

This new ignition cycle of a concentrated mass of fairly large particles is illustrated by the curve of Figure 1, the times being indicated in abscissas and the temperatures of the mass being indicated in ordinates.

Starting from the time of origin A, at the ambient temperature, in the first seconds, the user cuts in chips with a cutting tool the small pyrophoric rod, in the bottom of the crucible: the heating resulting from this cutting raises the temperature of the mass of chips up to, for instance, about 100° C. (curve AB).

In a free space filled with agitated air, the particles of ferro cerium should be ignited at about 80° C. but, since they are produced without stirring and are accumulated in the bottom of a small crucible with little or no agitated air, they go through a combustion which, without being notable, can be assimilated to a slow combustion. During a few seconds, amounting for instance to fifteen seconds, the mass of the particles cools down, but very slowly, in the crucible (curve BC), remaining slightly above 80° centigrade. The time BC corresponds about, with a broad estimation, to the time necessary for the smoker, after the time AB devoted to the stripping of particles, to bring the particles and the tobacco in contact or in close vicinity.

Then, the smoker inhales, through the cigarette, cigar, or other draft medium the outer air which penetrates thereby in the crucible; the pyrophoric particles are briskly ignited and their temperature rises instantly, for instance up to about 800° C. (curves CD or CE according to the size of the particles). Thus the mass of tobacco, in contact with air heated by the ignition of the pyrophoric particles at this high temperature, receives, according to this improved cycle of ignition, together the large number of calories and the rise in temperature which are required for its good inflammation.

The invention will be described particularly with reference to a lighter for smokers.

This lighter is described hereinafter and illustrated in the annexed drawing in which:

Figure 1 illustrates the curve of the new cycle of ignition, as above explained.

Figures 2 and 9 are, at a very enlarged scale, diametrical sections of two embodiments of lighters.

The Figures 3, 4, 5, 6 show spare parts of either one or the other of these lighters.

The Figure 7 is an end elevational view of the Figure 6.

The Figure 8 is a plan view of the device shown in Figure 6.

According to Figure 2, the lighter has the shape of a large and short pencil as long as a cigarette, or about, but twice as thick.

The body of the lighter is in the front part and the mechanism is in the rear part.

3

The body of the lighter includes a tubular part, the front of which forms a recess 2, for the cigarettes.

In the body of the lighter is screwed by its enlarged end 3 a tube 4: the front of this tube 4 forming the crucible 5 is provided with a small fixed cutter 6 and the rear channel 4a supplies a passage for the small pyrophoric rod 7.

The cutter 6, located in two notches 5' in the edge of the wall of the crucible 5 has been shown as a spare part in Figure 6 as seen sideways, in Figure 7 as seen by end and in Figure 8 as seen from above. The cutter 6 has a slanting cutting edge 8, passing through the axis of the small pyrophoric rod 7. The upper part of this small rod, through the cutting of the tool, will take a conical shape having the same slope as the cutting edge 8 of the cutter.

The small pyrophoric rod 7 has, at its rear end, a slot 9 by means of which it can be set in rotation by the mechanism forming the rear part of the lighter.

This mechanism includes a socket 10, screwed in the tube 4. The socket contains a revolving driving rod 11, ending at its upper part in a tenon 12, which engages the rear slot 9 of the small pyrophoric rod and is pressed against this rod by a spring 13, having an adjusted tension; this spring bears, at its rear end upon a revolving stop washer 13a, which in turn, bears upon a fixed stop washer 13b, located in the bottom 16 of the socket 10 and bears, at its front end, upon the flange 11a of the rod 11. The driving rod 11 passes freely through the bottom 16 of the socket 10 and its end is made secure with an operating knob 14, the front face of which is strongly pressed by the spring 13 against the bottom 16 of the socket 10, with the interposition of a loose disk of a friction-clutch 17, made preferably of a plastic material, particularly of non plastified vinyl chloride.

A small air inlet duct 18, communicating with the outside through a port 19 and a peripheric groove 20 ends in the bottom of the crucible 5, just above the small pyrophoric rod 7 and in front of the edge of the cutter 6. This baffle shaped passage hinders the inopportune air intakes which could give rise to agitation. A cap, 21, with at its bottom an off-centered hole 22 is mounted on the front part of the lighter and is held by a boss or a screw 23, to turn of half a turn, thus allowing to open and to close the lighter.

The functioning of the lighter is as follows:

By revolving once or several times the knob 14, the user sets in rotation against the edge 8 of the cutter 6, the small pyrophoric rod 7, the conical edge of which has the same slope as the cutter. The cutter will therefore strip, all along its cutting edge, in contact with a generatrix of the cone, chips, fairly large if compared with the ferro cerium particles which were stripped off and projected by the milling wheel of the conventional lighters. These chips, produced with a minimum stirring and without agitation of air produced by the moving element (the small pyrophoric rod has no projections and turns about its axis with a comparatively low speed) gather in the very small crucible 5. Despite their temperature of about a hundred degrees resulting from the cutting work, these pyrophoric particles are but a little ignited. The smoker has at his disposal fully the few seconds necessary to introduce his cigarette in the recess 2, to place the cigarette in his mouth, holding the lighter aligned with the cigarette and to inhale: the air penetrates violently in the bottom of the crucible, giving thereby rise to the spontaneous combustion of the particles together with an increase of temperature, this physical phenomenon creating the required conditions for a quick and easy lighting of the tobacco.

To secure good conditions for the stripping of the small pyrophoric rod, it is necessary that the pressure of the spring 13 on the small pyrophoric rod, and thereby the pressure of the rod against the cutter remains rigorously constant.

4

Therefore the spring pressing against the small pyrophoric rod is carried by a member which progresses in the body of the lighter to follow step by step the displacements resulting from the wear of the small rod, this result being obtained by the fact that the member carrying the spring is displaced by the device controlling the rotation of the small rod, by means of a friction connection depending on the release of the spring.

When the pressure exerted by the spring 13 upon the pyrophoric rod 7 is not sufficient to allow the cutting tool to penetrate the rod 7 and to strip off large particles, the rotation of the knob 14 is transmitted through the friction disk 17 to the socket 10 which is screwed on the body 4 of the lighter, thus compressing the spring 13. As soon as the compression of spring 13 is sufficiently large to cause the tool 6 to deeply penetrate into the pyrophoric rod 7 in order to strip off large particles, the compression of said spring opposes an increased resistance to a further upward displacement of the socket 10 so that a sliding occurs at one of the faces of the friction disk 17 and the driving rod 11 is alone rotated whereas the socket 10 is immobilized.

Upon a certain wear of the pyrophoric rod 7, the spring 13 slackens and the resistance opposed to the rotation and upward movement of socket 10 is decreased, so that said socket is further rotated by the knob 14 through the friction disk 17 whereby the desired compression of the spring 13 is restored.

It may be necessary to produce for the lighting of some cigarettes, particles or chips larger as for others and this can be obtained by adjusting the scale of the spring. This adjustment becomes also necessary when eventually the cutter becomes dull.

The spring acting upon the pyrophoric rod, instead of bearing on a shoulder 11a of the driving rod 11 as shown in Fig. 2, is provided at its upper end with an adjustable stop of which the position on the driving rod 11 may be easily varied. Fig. 9 shows said spring adjusting means as applied to the structure shown in Fig. 2. The revolving driving rod 24, bearing a tenon 12, extends towards the bottom in a hollow tube 26; the rear end of which is secured to the driving knob 25, the tube 26 bears two lateral slots, 27. In the tube 26 is guided a rod 28, provided with a transverse pin 29 bearing on the flange 30a of a socket 30 sliding on the tube 26 and forming an adjustable stop for the spring 31. The rod 28 passes freely through the driving knob 25 and its end is screwed in a nut 32. By turning the nut, either one way or the other, the rod is moved upwardly or downwardly and, the socket 30 is moved therewith, thus modifying the tension of the spring 31.

As it is necessary to avoid to the utmost the losses in calories, it is advisable to make the lighter nearly entirely of an insulating material, particularly with plastic materials combined with asbestos, mica, glass, or the like.

To prevent the very thin dusts coming from the crucible from penetrating in the lower part of the mechanism when, after the wear out of several small pyrophoric rods, the tube 4 becomes possibly out of round and also to meet the wear of the cutter, it has been foreseen that the unit including the member carrying the crucible, 3—4, the cutter 6 and the small pyrophoric rod 7 should be, after the wear of a single pyrophoric rod, replaced by a new unit, as the price of the small pyrophoric rod is little increased by the adjunction of the member carrying the crucible and guiding the pyrophoric rod, and of the cutter. The user will thereby, have at his disposal an always new cutting and guiding mechanism.

What we claim is:

1. A pyrophoric lighter for smokers comprising, a casing, an upwardly open chamber of small size in the

5

form of a crucible provided at the upper end of said casing, a central cylindrical vertical duct provided in said casing and opening into the bottom of said chamber, a pyrophoric rod guided in said duct and penetrating into said chamber, a fixed tool having a cutting edge operable for cutting mounted in the bottom of said chamber and having its cutting edge arranged in a vertical plane passing through the axis of said cylindrical duct, means pressing said pyrophoric rod against said cutting edge of the fixed tool, means to impart to said pyrophoric rod a rotary motion about its axis, whereby pyrophoric particles are stripped off the rod and accumulated in the bottom of the chamber, and an air inlet provided in said casing and extending from the exterior of said casing to near the bottom of said chamber.

2. A pyrophoric lighter for smokers, comprising an elongated tubular casing, a small cylindrical chamber at its upper end and extending upwardly in a slightly conical outlet into which the end of a cigarette may be introduced with a snug fit, a central opening provided in the bottom of said chamber and extending downwardly in a central cylindrical duct arranged in the casing, a cylindrical pyrophoric rod guided in said duct and penetrating into said chamber, a fixed tool having a cutting edge and operable for cutting secured in the bottom of said chamber and having its cutting edge obliquely arranged in a vertical plane containing the longitudinal axis of said cylindrical duct, means pressing said pyrophoric rod against said cutting edge of the fixed tool, means to impart to said pyrophoric rod a rotary motion about its axis whereby pyrophoric particles are stripped off the rod and accumulated in the bottom of the chamber, and an air inlet provided in said casing and extending from the exterior of said casing to near the bottom of said chamber.

3. A pyrophoric lighter for smokers comprising a first tubular member provided at its upper end with a conical outlet adapted to receive the end of a cigarette with a snug fit, and at its lower end with a cylindrical recess, a second tubular member having its upper end removably fitted into said lower recess of the tubular member and provided at said upper end with a small cylindrical chamber opening into said conical outlet of said tubular member, an axial duct bored into said cylindrical member and opening in the bottom of said chamber, a pyrophoric rod guided in said duct and penetrating into said chamber, a cutting tool fixedly secured in said chamber and having its cutting edge obliquely arranged across the bottom thereof in a vertical plane passing through the axis of said duct, spring means for pressing said pyrophoric rod against said tool, a driving rod rotatably mounted inside said duct provided in said second tubular member, coupling means between the upper end of said driving rod and the lower end of said pyrophoric rod, a knob secured to the lower end of said driving rod to impart a rotational motion to the pyrophoric rod whereby pyrophoric particles stripped off said rod are accumulated in the bottom of the chamber, an air inlet formed by a narrow radial duct extending from the exterior of said cylindrical member and opening in the upper chamber of said member near the bottom thereof.

4. A pyrophoric lighter for smokers comprising a tubular member provided at its upper end with a conical outlet adapted to receive the end of a cigarette with a snug fit and at its lower end with a threaded cylindrical recess, an externally threaded cylindrical member provided with an enlarged externally threaded head screwed into said recess, a small chamber in the form of a crucible provided in said head and opening into the conical outlet

6

of the tubular member, an axial duct bored in said cylindrical member and opening in the bottom of said chamber, a pyrophoric rod guided in said duct to penetrate into said chamber and having a diametral slot at its lower end, a cutting tool fixedly secured in said chamber and having its cutting edge obliquely arranged across the bottom of said chamber in a vertical plane containing the axis of the said axial duct, an externally threaded socket screwed on the lower end of said cylindrical member and having a central opening in its bottom, a radial air inlet extending from the exterior of the said head and opening into the chamber near its bottom, a driving rod axially located inside said socket, projecting outwardly through the opening thereof and provided at its upper end with a tenon engaging the slot of the pyrophoric rod, a helical spring bearing by its lower end against the bottom of the socket and by its upper end on a flange of the driving rod to press the same against the cutting tool, a knob rigidly secured on the lower free end of the driving rod projecting through the bottom of the socket, a friction disk arranged between the bottom of said socket and the knob to impart a rotational motion to said socket and the screwing thereof on the threaded cylindrical member whereby the compression of the spring is obtained.

5. A pyrophoric lighter for smokers comprising a tubular member provided at its upper end with a conical outlet adapted to receive the end of a cigarette with a snug fit, and at its lower end with a threaded cylindrical recess, an externally threaded cylindrical member provided with an enlarged externally threaded head screwed into said recess, a small chamber in the form of a crucible provided in said head and opening into the conical outlet of the tubular member, an axial duct bored in said cylindrical member and opening in the bottom of said chamber, a pyrophoric rod guided in said duct to penetrate into said chamber and having a diametral slot at its lower end, a cutting tool fixedly secured in said chamber and having its cutting edge obliquely arranged across the bottom of said chamber in a vertical plane containing the axis of the said axial duct, an externally threaded socket screwed on the lower end of said cylindrical member and having a central opening in its bottom, a radial air inlet extending from the exterior of the said head and opening into the chamber near its bottom, a driving member axially located inside said socket and projecting outwardly through the opening in said socket, a transverse pin carried by said driving member in its upper part, a tube surrounding said rod and having two lateral vertical slots through which extend the ends of said pin, the lower end of said tube also projecting outwardly through the opening of the bottom of the socket, a cylindrical member adapted to slide on said tube and having an annular upper flange, a helical spring bearing by its lower end on the bottom of the socket and by its upper end on said flange, a knob rigidly secured on the free lower end of said tube, threads provided on the free lower end of the driving rod projecting outwardly from said tube, a nut freely mounted on the lower face of the knob and engaging the free lower threaded end of the driving rod, a friction disk arranged between the bottom of said socket and the knob to impart a rotational motion to said socket and the screwing thereof on the threaded cylindrical member whereby the compression of the spring is obtained.

References Cited in the file of this patent

UNITED STATES PATENTS

1,782,544	Myers	Nov. 25, 1930
2,638,763	D'Alton	May 19, 1953