

(No Model.)

J. H. FARREL.
POCKET LAMP.

No. 451,301.

Patented Apr. 28, 1891.

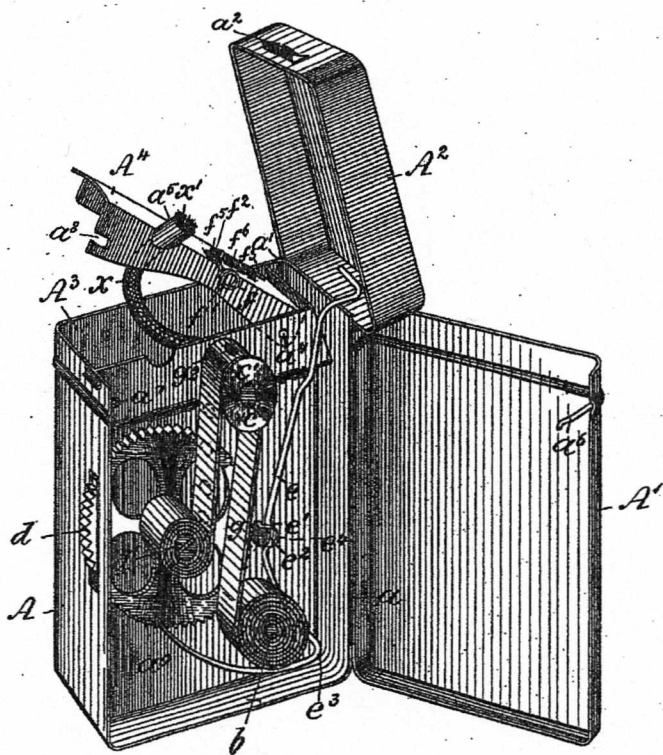

Witnesses:
Karlmann Bormann
Thomas M. Smith.

Inventor:
John Harry Farrel,
by J. Walter Songlass.
Att'y.

(No Model.)

J. H. FARREL.
POCKET LAMP.

No. 439,578.

Patented Oct. 28, 1890.

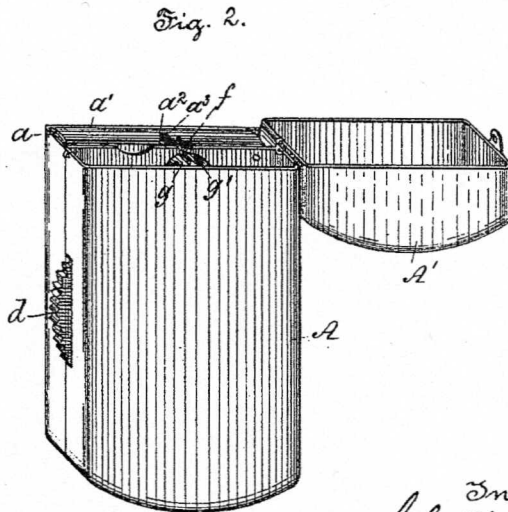
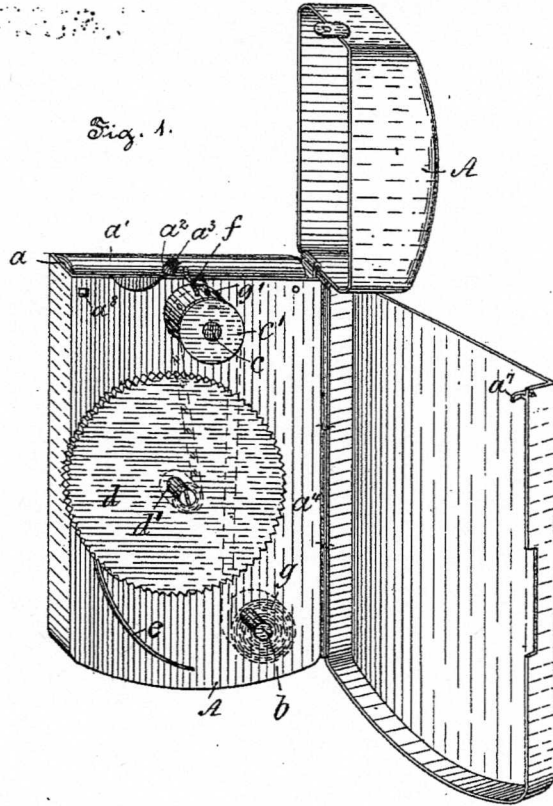

Witnesses:
Kernann Borman
Richard C. Maxwell.

Inventor:
John H. Farrel,
J. C. Walter & Douglass,
att'ys.